

•K'DAL•

collerette pour dalles LED

par



WOOD LIGHT

SINCE 2020

KRAKEN LIGHTING

MADE IN FRANCE



ESSENCES ET FINITIONS



CHÊNE
NATUREL NATURAL
OAK



FRÊNE
NATUREL NATURAL
ASH



FRÊNE
BLANC WHITE
ASH



FRÊNE
BRUN BROWN
ASH

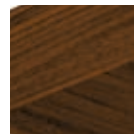

FRÊNE
TECK TEAK
ASH



FRÊNE
ACAJOU MAHOGANY
ASH



FRÊNE
WENGÉ WENGE
ASH

WOOD ESSENCE AND FINISHING

KDAL66

DESIGNED BY NIKOFORGET

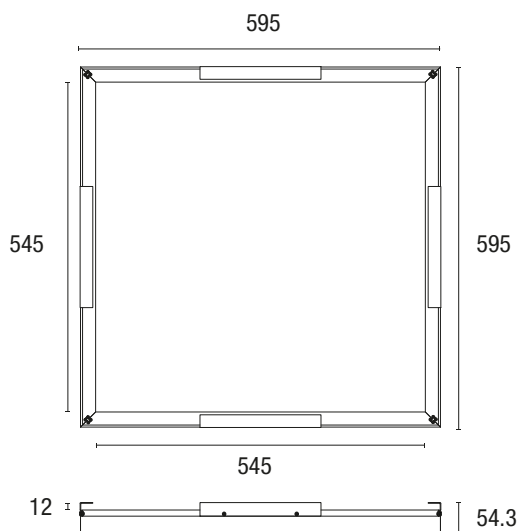

DESCRIPTIF GÉNÉRAL

Accessoire pour dalle LED 595x595mm

S'adapte à plus de 90% des dalles LED du marché

Cadre en bois massif issu de forêts françaises éco-gérées

Finition vernis M1

S'installe en encastré dans les plafonds modulaires

Maintient de la dalle par 4 étriers.

Dalle LED non incluse (en option)

Autres dimensions sur demande :

300x600, 300x1200, 625x625, 675x675...

GENERAL DESCRIPTION

Accessory for LED PANEL 595x595mm

Compatible with 90% of LED panels market

Solid wood frame from eco-managed French forests

M1 varnish finish

Installs recessed in modular ceiling

Maintains the panel with 4 brackets.

LED panel not included (optional)

Other sizes on request :

300x600, 300x1200, 625x625, 675x675...

Version 300x1200 sur demande / 300x600, 300x1200 version on request



Version 300x1200 sur demande / 300x600, 300x1200 version on request

KDAL66 - À MONTER



POURQUOI LIVRER EN KIT ?

Ce n'est pas par fainéantise, mais par bon sens.

Livrer un cadre rempli de vide, serait un non sens à plusieurs points.

- Diminuer les coûts de transports
- Diminuer les risques de casses lors du transport
- Diminuer les coûts de stockage

Nous avons donc étudié un montage optimisé, sans colle, rapide et qui garantit un assemblage propre et costaud.



WHY IN KIT DELIVERY?

This is not out of idleness, but out of common sense.

Delivering an empty frame would be a nonsense

- Reducing shipping cost
- Reducing broking risks during shipping
- Reducing storage costs

We therefore studied an optimized assembly, without glue, fast and which guarantees a clean and strong assembly.

ETAPE 1 :

Assembler le cadre bois

Nécessite de travailler sur un plan de travail propre et plat

STEP 1 :

Assemble wood frame

Be careful to work on straight and clean workspace





ETAPE 2 :
Assembler 3 équerres sans serrer définitivement
Ils permettent de maintenir la dalle LED au cadre.
Les moulures bois sont pré-percées
Visserie fournie

STEP 2 :
Assemble 3 brackets without definitely fix it.
It hold led panel to wood frame
Wood moldings are pre-drilled
Screws provided



ETAPE 3 :
Intégrer la dalle
Après avoir assemblé 3 équerres
Faire glisser la dalle.
Fixer la quatrième équerre et serrer définitivement.
L'ensemble ne formant plus qu'un,
Vous pouvez mettre le filin de sécurité fourni avec votre dalle LED.

STEP 3 :
Put the panel
After screw 3 brackets
Insert LED panel
Fixed the fourth bracket and fix it definitely.
The whole thing becomes one, you can put the safety wire supplied with your LED panel.

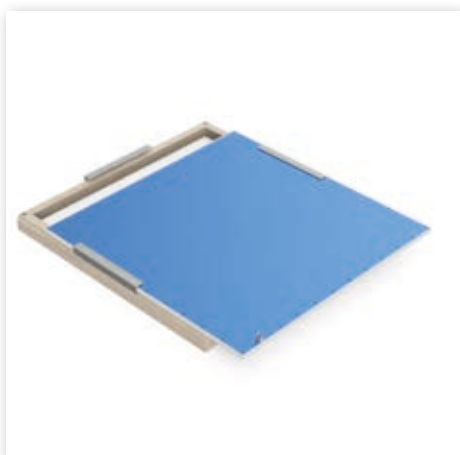



FRÈNE
BLANC

WHITE
ASH

FRÈNE
TECK

TEAK
ASH

FRÈNE
AÇAJOU

MAHOAGANY
ASH

FRÈNE
WENGÉ

WENGE
ASH



FRÈNE
NATUREL

NATURAL
ASH



CHÈNE
NATUREL

NATURAL
OAK



FRÈNE
BRÛN

BROWN
ASH



WOOD LIGHT

SINCE 2021

KRAKEN LIGHTING

MADE IN FRANCE